

WATER-OIL CAPILLARY PRESSURE AND WETTABILITY MEASUREMENTS USING MICROPORE MEMBRANE TECHNIQUE

Daniel LONGERON, Institut Français du Pétrole, France

Wibeke L. HAMMERVOLD, RF-Rogaland Research, Norway

Svein M. SKJAEVELAND, Rogaland University Center, Norway

Abstract

This paper describes a new technique to simultaneously measure the capillary pressure curves and wettability indices for an oil - brine - rock system. By improving the porous plate method, the full cycle of four capillary pressure curves, i.e. spontaneous and forced drainage and imbibition, is measured in days instead of months. This is achieved by the use of thin oil- and water-wet micropore membranes and short samples with large diameter.

Measurements have been done on sandstone and carbonate outcrop cores with wettabilities ranging from strongly water-wet to oil-wet. A reduction in experimental time by a factor of 10 or more is gained by the new method for a full cycle of the four capillary pressure curves.

In addition, a new measure of wettability is suggested as an improvement of the USBM test, incorporating all four areas between the capillary pressure curves and the saturation axis. The new wettability index may be conceived as an extension of the Amott test, with the four saturation intervals weighted by the corresponding areas under the capillary pressure curve and may better discriminate between mixed-wet and spotted-wet samples.

INTRODUCTION

Knowledge of the water-oil capillary pressure vs. saturation relationship is necessary for many reservoir engineering tasks like: (1) assess connate water saturation to calculate oil-in-place; (2) determine the height of the transition zone; and (3) model oil displacement either by free water imbibition and/or water injection.

During the last ten years, much work has been done to improve the laboratory procedures for measurement of water-oil relative permeabilities. Less effort has been made to improve the determination of capillary properties, probably because it is difficult to measure capillary pressure at representative reservoir conditions.

This paper presents improvements in measuring complete capillary pressure curves for different wettabilities. The diaphragm method is very accurate and reliable and so far the only method that may give the full loop of capillary pressure curves, forced and spontaneous drainage and imbibition, but has been extremely time consuming. However, recent work^{1,2} has shown a significant reduction in experimental time if thin micropore membranes are used instead of porous disks for drainage capillary pressure measurements. Now, this method is extended to the full cycle of capillary pressure curves.

A new coreholder cell, together with two thin membranes and specific procedures, has been developed and tested on sandstone and carbonate cores. Full cycles of capillary pressure curves were obtained, and in addition, the concept of wettability has been

quantified by a new index that takes into account the areas between the the capillary pressure curves and the saturation axis.

EXPERIMENTAL

Equipment

The main problems have been (1) to seal the membrane to keep fluid from passing around its outer perimeter; and (2) to protect the membrane from being penetrated by the rough surface of the core sample.

A simpler coreholder has been constructed with better arrangement of the membranes. It consists of three parts; two endpieces that can be dismantled separately and a cylinder which contains the coated core. The coating is a low melting point alloy ($T_f = 124^\circ\text{C}$). The core and the coreholder are being soldered together into one piece. The endpieces have two connecting tubes, so a circulation of fluid is possible (without fluid entering the core). This is to ensure complete saturation of the endpiece and membrane arrangement after the core is mounted. The diameter of the core is 5 cm and the thickness 2 cm.

Axial pressure is applied by tightening six screws around each endpiece going into the cylinder wall. A radial confining pressure is applied to the core by the solidified metal.

Fig. 1 shows the coreholder and endpiece. Previous tests demonstrated that the endpiece with an O-ring and a metal support screen made a good seal and support of the membrane when the coated core was pressed against the endpiece. Fig. 1 also shows the arrangement of the micropore membrane.

Data for the membranes used in the experiments are listed in Table 1.

Arrangement

The cycles of capillary pressure curves were obtained by using thin water-wet and oil-wet membranes. Fluids were brine, refined oil and crude oil. The membranes could be replaced during the experiment.

The displaced fluid was produced at atmospheric pressure and the amount recorded by an optical device connected to a micropump which again was connected to a plotter. The differential pressure was applied either by a pressure cell containing oil and nitrogen or by an oil column (for the pressures below 200 mbar) with good accuracy for the differential pressure at low values. When measuring spontaneous imbibition of water, the oil pressure is decreased, and a burette is placed at the outlet end to measure the amount of water imbibed. For the forced imbibition curve, the brine pressure is applied in the same manner as for oil pressure during drainage; first by the water column head, and then by a pressure cell containing water and nitrogen.

Experiments

Two types of cores have been used, Vosges sandstone and Estailade carbonate (both outcrops). They are both naturally water-wet when cleaned and dried. One core of each material was aged in crude oil and another was measured at native water-wet conditions. Capillary pressure cycles consisting of four curves, subsequent to the primary drainage, was measured on four different cores. An Amott-IFP³ test was performed on similar core plugs, both for untreated and aged cores, to check the effectiveness of the aging procedure, Table 4, right column.

Drainage curves for water-wet cores was measured by the membrane technique, the standard porous plate technique and by mercury injection for comparison.

Fluids used were brine, refined oil and crude oil. Lagrave crude oil was chosen since it has a high content of polar components and thereby the ability to make the rock surfaces more oil-wet. Core and fluid data are listed in Tables 2 and 3.

Procedure

Water-wet cores

The core was initially saturated with brine and a water-wet membrane was placed in the coreholder. Primary drainage with Soltrol down to irreducible water saturation gave the starting point of the capillary pressure cycle. First, spontaneous imbibition of water was performed down to zero capillary pressure, and an oil-wet membrane was mounted. Forced imbibition of water was then followed by spontaneous imbibition of oil and then secondary drainage to complete the cycle.

Intermediate-wet cores and aging procedure

Primary drainage from 100% water saturation was performed with crude oil. The core was aged at residual water saturation at a temperature of 60°C for 4 weeks. Then two different procedures were followed to replace the crude oil by refined oil: (1) first a gentle cleaning of the core was performed by circulation of cyclohexane and isopropyl alcohol and then the core was resaturated with brine and the capillary pressure cycle measured according to the same procedure as for water-wet cores; (2) the crude oil was displaced by refined oil directly, and the spontaneous imbibition curve was measured after replacing the water-wet membrane and reapplying the capillary pressure used to reach S_{wi} . At zero capillary pressure, the oil-wet membrane is mounted and forced imbibition, spontaneous drainage and secondary drainage curves are measured. Procedure 1 was used for the aged carbonate core, and procedure 2 was used for the aged sandstone.

It is possible to mount both of the membranes from the beginning of the experiment, but the method above was preferred since the oil-wet membrane is not necessary when measuring drainage and spontaneous imbibition curves of water and may only increase the experimental time.

WETTABILITY

Wettability is one of the most important factors controlling multiphase flow in reservoir rock. It influences fluid location, flow, distribution and trapping. The wettability affects almost all types of core analysis: Capillary pressure, relative permeability, electrical properties, irreducible saturation, and many EOR-processes.

The two most used methods for quantification of wettability are the USBM⁴ and the Amott⁵ method.

Wettability has been classified as homogeneous when the rock surface has uniform molecular affinity to both water and oil, and heterogeneous when distinct surface regions have different affinity to water or oil. Homogenous wettability is again split in strongly water-wet, strongly oil-wet, and intermediate-wet classes. Heterogeneous wettability may be divided into mixed-wet, when the rock has continuous water-wet and oil-wet regions, and spotted- (fractional-) wet, when one phase is continuous and the other discontinuous.

Recent work has shown that the wettability is heterogeneous on a pore scale for reservoir rocks⁶. Radke et al.⁷ have studied wettability on the pore scale and explain how mixed wettability may develop in terms of thin films.

For classification and comparison between different reservoir materials, quantification of wettability is necessary. Especially there is a need for better quantification and understanding of the heterogeneous wettability conditions.

Attempt to assign a new wettability index; the HL-Index

Data from the spontaneous imbibition and drainage processes are not included in the calculation of the USBM index. It seems intuitively reasonable that these processes also would characterize the wettability of the system and should be included in an overall wettability index for the sample. Consequently, a new wettability index is suggested, the Hammervold-Longeron index I_{HL} (Eqs. 1-3). The new index may be able to distinguish between mixed- and spotted-wet samples, since a spotted-wet sample would spontaneously imbibe more of the continuous wetting phase than the discontinuous (spotted) phase, and a mixed-wet sample would spontaneously imbibe both fluids. In contrast, an intermediate (homogeneous) core would not imbibe in any direction.

$$I_{HL} = I_w - I_o, \quad (1)$$

where

$$I_w = B_1 / (B_1 + A_2), \quad (2)$$

and

$$I_o = B_2 / (B_2 + A_1), \quad (3)$$

where B_1 is the area under the spontaneous imbibition curve, A_2 is the area under the forced imbibition curve, B_2 the area under the spontaneous drainage curve, and A_1 the area under the secondary drainage curve, Fig. 2. The absolute values of the areas are used.

RESULTS

Drainage capillary pressure curves were measured by different methods to verify the new membrane measurement technique. A whole capillary pressure loop for four different cores (using membrane technique) were measured with corresponding HL-index measurements to study the applicability of the index.

Figs. 3 and 4 show a comparison between drainage capillary pressure curves obtained by the membrane technique and by mercury injection for water-wet carbonate and sandstone cores. There is a good agreement between the two measurement techniques, as expected. Mercury injection is believed to be a representative method for measurement of the first part of the drainage curve for water-wet samples⁸.

Fig. 4 also shows a comparison between drainage capillary pressure curves obtained by the membrane technique and by the traditional porous plate method using a sintered alumina plate.

Four complete capillary pressure loops (after primary drainage) with spontaneous imbibition, forced imbibition, spontaneous drainage (imbibition of oil) and secondary drainage curves have been measured by the membrane technique on two Vosges sandstone cores, Figs. 5 and 6, and two Estailade carbonate cores, Figs. 7 and 8; for each rock type on both a water-wet core and one aged in crude oil. (The drainage curve for experiment No.2, Fig.6, is not reported).

The HL-index was calculated for the four cores. The areas was calculated by a computer program using the measured data points. Also the Amott- and the USBM-index can be calculated from the data, although the method originally described for these tests is not

used. The Amott-index is defined by; $I_{O-W} = I_O - I_W$, where $I_W = a/(a+b)$, and $I_O = c/(c+d)$. a is the saturation change during a spontaneous imbibition in water, b is the saturation change during a forced imbibition (decreasing oil saturation), c is the saturation change during a spontaneous imbibition in oil, and d is the saturation change during a secondary drainage (decreasing water saturation). The standard USBM-index is calculated using capillary pressure curves from measurements by centrifuge. The wettability index is defined by $I_{USBM} = \log(A_1/A_2)$, where A_1 is the area between the drainage curve and the saturation axis and A_2 is the area between the imbibition curve and the axis.

For the calculation of the Amott index, the saturation intervals are taken from the membrane measurements. For the calculation of the USBM-index, the areas under the secondary drainage and forced imbibition curves from the membrane measurement (denoted by A_1 and A_2 in Fig. 2) are used. The wettability indices are listed in Table 4.

Discussion

A. Aging procedure

The aged carbonate core, Fig. 8, was cleaned gently and resaturated (procedure 1) before the capillary pressure curves were measured. Compared with the aged carbonate core from the Amott-IFP test, Table 4, which was not cleaned after aging (procedure 2), we see a difference in wettability index (comparing all three indices) towards a more oil-wet core when following procedure 2.

The aged sandstone, Fig.6, and the core used in the Amott-IFP test both followed aging procedure 2. The difference between the three indices for experiment 2 may be due to membrane damage since the secondary drainage curve had to be stopped at 100 mbar. Area A_1 is therefore cropped and the HL-index too high.

The sandstone core, from the Amott-IFP test, is still water-wet after aging, in agreement with the HL-index, while the other two indices indicate a neutral core. According to most tests, the carbonate core is easier to make oil-wet than the sandstone core, but the gentle cleaning procedure evidently affects wettability in a less oil-wet direction. The scale for the Amott indices and the HL-index is the same; from -1 to +1. For the USBM index the scale is from $-\infty$ to $+\infty$, in practice from -2 to +2, and can therefore not be compared directly with the other indices.

B. The HL-index.

Calhoun⁹ states that the entire capillary pressure sequence should be used as a measure of wettability, by comparing the capillary pressure curves. Gatenby and Marsden¹⁰ suggested the possibility of correlating wettability with the area of the hysteresis loop or other areas between the capillary pressure curve and the saturation axis. Morrow¹¹ states that wettability of a porous medium relates to the surface energetics of displacement, but is not a well-defined term, and Brown and Neustadter¹² suggest that the definition of the term wettability requires reference to the total system of solid plus fluids considered together with the kinetics of the displacement.

We suggest that the term wettability should express the overall tendency of a fluid spontaneously to imbibe as compared with its susceptibility to forced imbibition, when the whole saturation range is covered. More precisely, how much energy is released during spontaneous imbibition as compared with what is stored during forced imbibition. By this definition, the wettability is not a function of saturation, but an overall tendency of a reservoir rock to prefer one fluid over another.

For a reversible process, the area under the capillary pressure curve, i.e.

$$\int P_c dS_w,$$

is equal to the amount of free energy the core-fluid system may exchange with its surroundings¹¹. The integral is negative when the system energy is increased and positive when energy is transferred to the surroundings.

Starting at irreducible water saturation, in Fig. 2, for a water-wet core, spontaneous imbibition down to zero capillary pressure results in release of stored energy equal to B_1 .

Next, forcing water into the core, the area A_2 (considered a positive quantity) is equal to the energy stored into the system, for a reversible process. The sum $B_1 + A_2$ is the total energy transfer over the saturation range and will be used as a normalizing quantity.

Area B_1 represents the "suction energy" or potential energy stored because water is the wetting fluid. The energy of the rock-fluid system is lowered by this amount when water imbibes. Likewise, the area B_2 represents the energy released by spontaneous imbibition of oil.

If no Haynes jumps take place, hysteresis is absent¹¹ and the complete cycle of drainage and imbibition is reversible. (This would for instance be the case for pore channels that are conical in shape, without any restricting pore throats.) Then $A_1 = B_1$, $A_2 = B_2$, $I_w = A_1/(A_1 + A_2)$, $I_o = A_2/(A_1 + A_2)$, and the new wettability index for the reversible case is $I_{HL} = (A_1 - A_2)/(A_1 + A_2)$, i.e. the normalized difference between energies released by spontaneous imbibition of water and oil, respectively.

In an actual core, the pore channels form bodies and throats and the capillary pressure curve will exhibit a hysteresis loop. As for ferromagnets¹³ the area of the loop is equal to the energy lost, ultimately as heat, per cycle, caused by irreversible Haynes jumps. In this case $A_1 \neq B_1$ and $A_2 \neq B_2$ and the new index is defined by Eqs. 1-3. By this choice, the definition is an extension of the Amott index, with the saturation intervals replaced by the corresponding integrals or energies.

In a recent paper by Toledo, Scriven and Davies¹⁴ it is shown by Monte Carlo simulations of volume-controlled mercury porosimetry of biconal pore segments that the area of the hysteresis loop depends on the aspect ratio, the ratio between the size of a pore body and a throat. A large contrast between body and throat results in more pronounced Haynes jumps and energy losses. Therefore, if the HL-index is measured, it should be possible also to interpret the shape and area of the hysteresis loop to find descriptive parameters of the pore network.

So far we have not checked the reproducibility of the hysteresis loop, but we note from the work by Radke, Kovscek, and Wong⁷ that the wettability may change depending on the maximum (and minimum) capillary pressure for a loop. Therefore, to reproduce the wettability index I_{HL} and the hysteresis loop, the minimum and maximum capillary pressure probably need to be kept fixed at relevant limits for field operations.

Conclusions

1. The micropore membrane technique for capillary pressure measurements is demonstrated to be an accurate and reliable method. Mercury injection (scaled) and traditional porous plate drainage curves show a very good agreement with the membrane data.
2. The reduction in experimental time for this new technique with micropore membranes and reduced length of the core, is significant (30 times faster than standard porous plate).
3. A full cycle of capillary pressure curves (four curves subsequent to primary drainage) has been obtained for water-wet and intermediate-wet cores within 20-30 days. The shape of the capillary pressure curves for different core samples reflects the wettability of the core.

4. A new wettability index is suggested that takes into account the areas of the four capillary pressure curves defining the hysteresis loop. The index may better quantify the wettability of a sample and discriminate between intermediate-wet, mixed-wet, and spotted-wet conditions.

Nomenclature

a :	saturation interval	S :	saturation
A_1 :	area under the secondary drainage curve	T_f :	melting temperature for metal alloy
A_2 :	area under the forced imbibition curve	ρ :	density
b :	saturation interval	ϕ :	porosity
B_1 :	area under the spontaneous imbibition curve	σ :	interfacial tension
B_2 :	area under the spontaneous drainage curve	θ :	contact angle
c, d :	saturation intervals	μ :	viscosity
I :	wettability index		
I_{Amott} :	Amott-index	Subscript	
I_{USBM} :	USBM-index	c :	capillary
I_{HL} :	HL-wettability index	g :	gas
k :	permeability	i :	irreducible
P :	pressure	o :	oil
PV:	pore volume	r :	residual
		w :	water

Acknowledgement

We would like to thank ARTEP, Elf, TOTAL, IFP (Institut Français du Pétrole), and ESSO Norge for financial support.

References

1. Hammervold, W.L. and Skjæveland, S.M.: "Improvement of Diaphragm Method for Capillary Pressure Measurement with Micro Pore Membrane", *Advances in Core Evaluation III*, Worthington, P.F. and Chardaire-Rivière, C. (ed.), Gordon and Breach Science Publishers, (1992) 91–111.
2. Guo, Y. and Hammervold, W.L.: "Equilibrium Time and Accuracy of Capillary Pressure Measurement Using Diaphragm Method," paper presented at the 1993 SPWLA Annual Symposium, Calgary, June 13–16.
3. Cuiec, L.E.: "Evaluation of Reservoir Wettability and Its Effect on Oil Recovery," *Interfacial Phenomena in Petroleum Recovery*, Morrow, N. R. (ed.), Surfactant Science Series, Marcel Dekker, Inc., New York (1991) 36, 334–6.
4. Donaldson, E.C., Thomas, R.D., and Lorenz, P.B.: "Wettability Determination and Its Effect on Recovery Efficiency," *SPEJ* (March 1969) 13–20.

5. Amott, E.: "Observations Relating to the Wettability of Porous Rock," *Trans. AIME* (1959) **216**, 156–162.
6. Fassi-Fihri, O., Robin, M., and Rosenberg, E.: "Wettability Studies at the Pore Level: A New Approach by the Use of Cryo-Scanning Electron Microscopy," paper SPE 22596 presented at the 1991 SPE Annual Technical Conference and Exhibition, Dallas, Oct. 6–9.
7. Radke, C.J., Kavscek, A.R., and Wong, H.: "A Pore-Level Scenario for the Development of Mixed-Wettability in Oil Reservoirs," paper SPE 24880 presented at the 1992 SPE Annual Technical Conference and Exhibition, Washington, DC, Oct. 4–7.
8. Omoregie, Z.S.: "Factors Affecting the Equivalency of Different Capillary Pressure Measurement Techniques," paper SPE 15384 presented at the 1986 SPE Annual Technical Conference and Exhibition, New Orleans, Oct. 5–8.
9. Calhoun, J.C.: "Criteria for Determining Rock Wettability," *Oil & Gas Journal* (May 10, 1951) **50**, No.1, 151.
10. Gatenby and Marsden: "Some Wettability Characteristics of Synthetic Porous Media," *Producers Monthly* (Nov. 1957) **22**, No. 1, 5–12.
11. Morrow, N.R.: "Physics and Thermodynamics of Capillary Action in Porous Media," *Ind. & Eng. Chem.* (June 1970) **62**, No. 6, 32–56.
12. Brown, C.E., and Neustadter, E.L.: "The Wettability of Oil/Water/Silica Systems with Reference to Oil Recovery," *J. Cdn Pet. Tech.*, (July-September 1980) Montreal, 100–110.
13. Feynman, R.P., Leighton, R.B., and Sands, M.: *The Feynman Lectures on Physics*, Volume II, Addison - Wesley, Reading, Massachusetts (1966).
14. Toledo, P.G., Scriven, L.E., and Davis, H.T.: "Pore-Space Statistics and Capillary Pressure Curves From Volume-Controlled Porosimetry," *SPEFE* (March 1994) 46–54.

Figures and tables

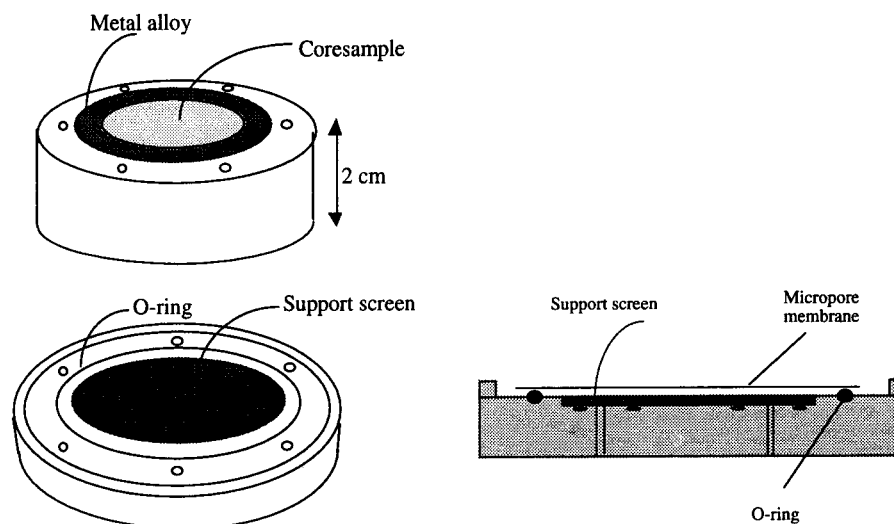

Fig. 1: The coreholder and endpiece (left) and a cross-section of the endpiece with membrane.

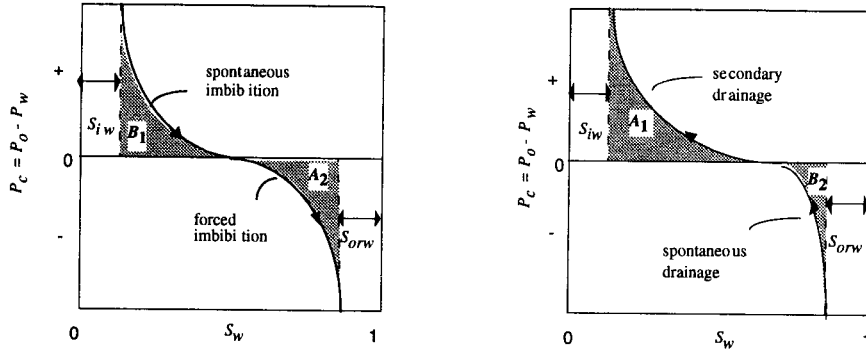

Fig. 2: Illustration of the areas used for the HL-index determination.

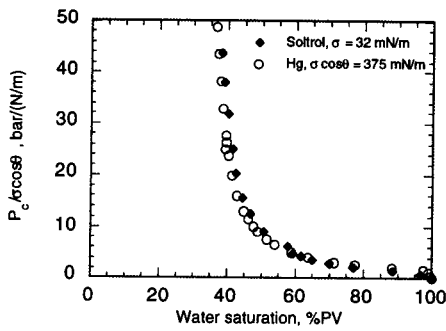

Fig 3: Drainage capillary pressure curves by membrane and mercury injection technique for Estailade carbonate.

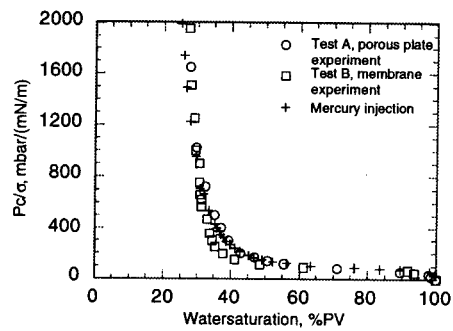

Fig 4: Drainage capillary pressure curves for Vosges sandstone by membrane, porous plate (disk of sintered alumina) technique and mercury injection.

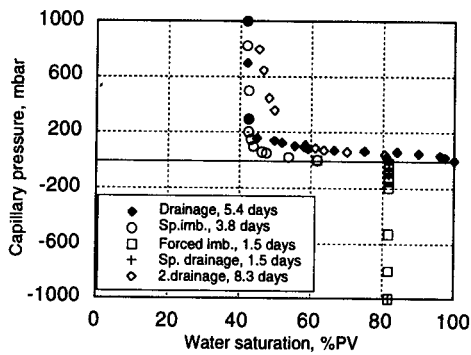

Fig 5: P_c loop (test No.1), Vosges sandstone, water-wet, $I_{HL} = 0.85$.

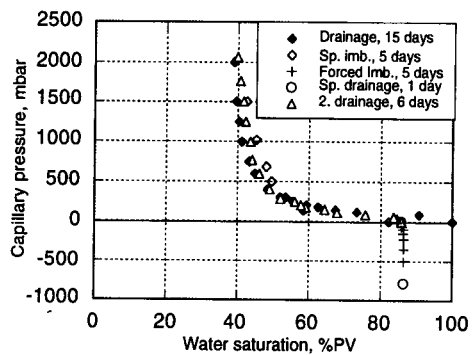

Fig 7: P_c loop (test No.3), carbonate core, water-wet, $I_{HL} = 0.97$.

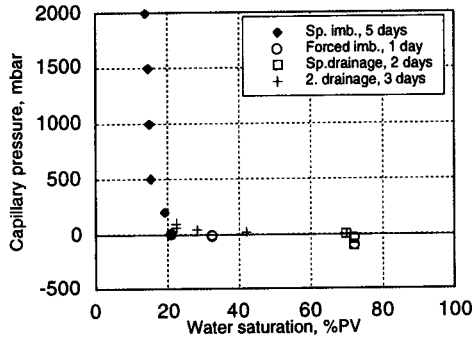

Fig 6: P_c loop (test No.2), Vosges sandstone, aged in crude oil, $I_{HL} = 0.65$.

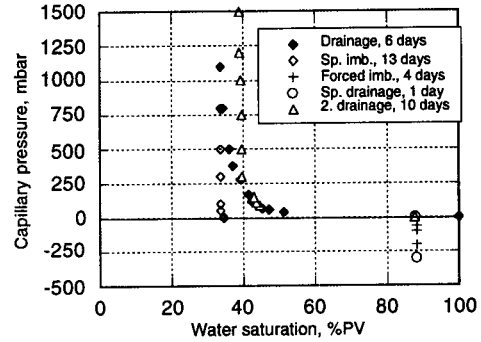

Fig 8: P_c loop (test No.4), carbonate core, aged in crude oil, $I_{HL} = -0.01$.

Table 1: Membrane data

Membrane type/material	Thickness (cm)	k_w (mD)	Poresize (μm)	PV (cm^3)
PTFE GoreTex (oil-wet)	0.008	0.22	0.02	0.1
Sartorius, cellulose triacetate (water-wet)	0.012	0.032	10 000 NMWCO [†]	
VVLP Millipore (water-wet)	0.015	0.9	0.1	0.29

[†]: NMWCO (Daltons) = nominal molecular weight cut-off is given instead of poresize.

Table 2: Core data

Test No.	1	2	3	4
core material	ss*	ss	c**	c
ϕ (%)	21.2	22.0	28.0	27.5
k_g (mD)	242	251	106	113
k_w (mD)	136	139	54	57
PV (cm^3)	8.10	8.58	10.9	10.8
Treatment	native	aged	native	aged

*: s = sandstone, **: c = carbonate

Table 3: Fluid data

Fluid	Type	ρ , g/cc (20°C)	μ , cp (20°C)
Brine	10 g/l NaCl	1.005	1.0
Oil	Soltrol 130	0.756	2.0
Crude oil	Lagrange	0.804	7.7

Table 4: Wettability indices

Core	Amott,	Modified USBM	HL-Index,	Amott-IFP
Vosges ss	0.50-0.00 = 0.50	1.47	0.85-0.00 = 0.85	0.78
Vosges ss aged	0.12-0.05 = 0.07	0.03	0.77-0.06 = 0.71	0.50
Carbonate	0.91-0.01 = 0.90	1.95	0.99-0.02 = 0.97	0.97
Carbonate aged	0.02-0.01 = 0.01	0.33	0.01-0.02 = -0.01	-0.44